

Specification 4172

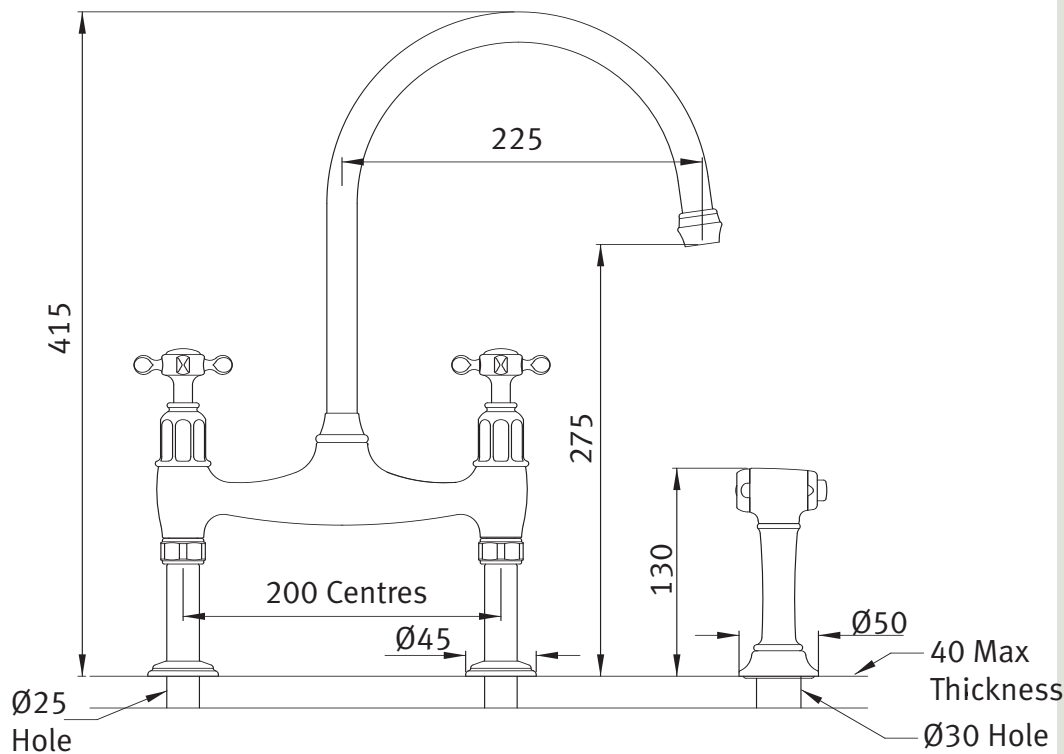

Ionian Two Hole Sink Mixer with Crosshead Handles and Rinse

- 1/4 turn ceramic disc flow control. ● vernier insert for accurate handle alignment.
- unique handle construction with integral bearing ring. ● Biflow



Temp Range:

min 1°C/34°F
max 85°C/185°F

Recommended working pressure:

min 0.2 bar/3psi
max 5 bar/75psi

Specification 4172



Ionian Two Hole Sink Mixer with Crosshead Handles and Rinse

- 1/4 turn ceramic disc flow control. ● vernier insert for accurate handle alignment.
- unique handle construction with integral bearing ring. ● Biflow

Where * Indicated Specify Colour.

