

# Specification 4387

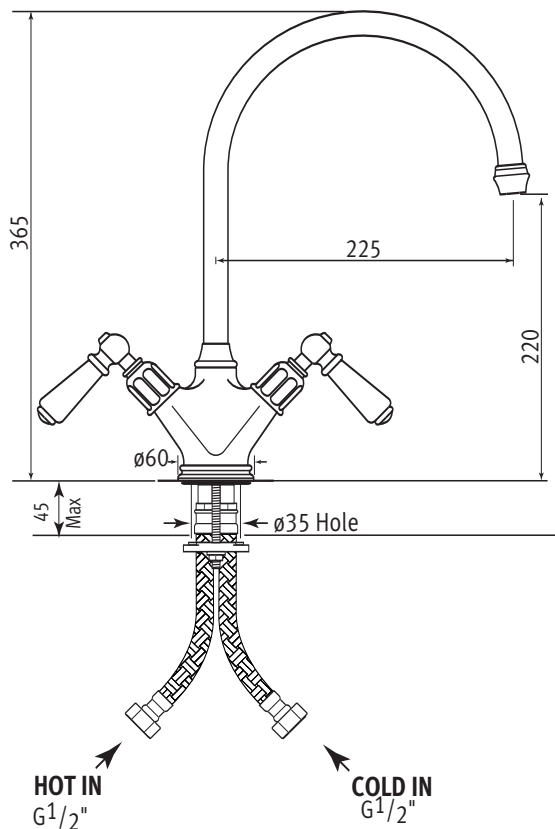

## Minoan Monobloc Mixer with Lever Handles

- 1/4 turn ceramic disc flow control. ● vernier insert for accurate handle alignment.
- unique handle construction with integral bearing ring. ● flexible connectors for easier installation.
- Biflow. ● Corian available.



### Temp Range:

min 1°C/34°F  
max 85°C/185°F

### Recommended working pressure:

min 0.2 bar/3 psi  
max 5 bar/75 psi



# Specification 4387



## Minoan Monobloc Mixer with Lever Handles

- 1/4 turn ceramic disc flow control. ● vernier insert for accurate handle alignment.
- unique handle construction with integral bearing ring. ● flexible connectors for easier installation. ● Biflow. ● Corian available.

Where \* Indicated Specify Colour.

