

Davos Specifications

- Quarter turn mixer
- Ceramic Disc Operation
- Attractive winged handles giving fingertip control
- Solid brass body
- Compatible with most Franke sink types
- Available in Chrome, SilkSteel & Fraganite colour finishes
- Requires 35mm tap hole
- Colour coded indices
- Conforms to W.R.C. requirements
- Fully guaranteed with nationwide servicing*

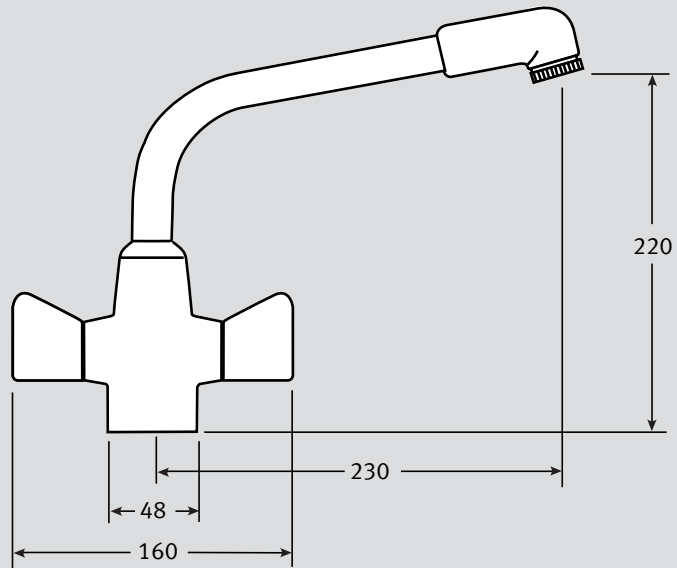

Material:	Solid brass body and tubular brass spout	
Type:	90° Quarter-turn mixer in brass	
Spout:	Tubular biflow spout with bayonet fitting into body secures by grub screw	
Tails:	Factory fitted screw-in 15mm copper tails. Supplied with fixing kit for body	
Tap Height:	220	
Spout Reach:	230	
Handle Width:	160	
Colours:	Chrome, SilkSteel, Fraganite White, Oatmeal, Champagne or Green.	
Maximum Water Pressure:	75 PSI (5 bar)	
Maximum hot-water Temperature:	70°C	
Recommended hot water Temperature:	65°C	
Guarantee:-	Ceramic disc:	5 year
	Surface:	1 year
Joints:	It is recommended that compression fittings are used to link the tap to the supply.	

Some taps may require bracing to avoid flexing of the sink ledge.

Tails:

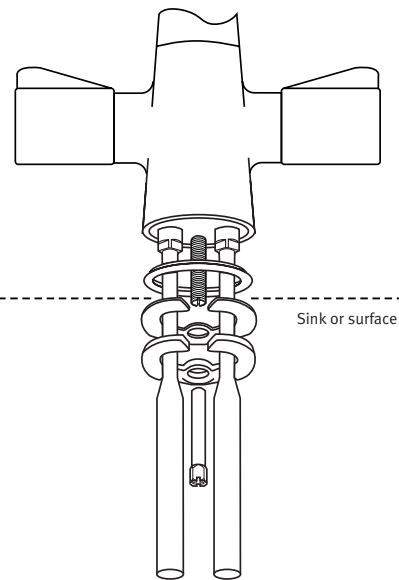

Valve Mechanism:

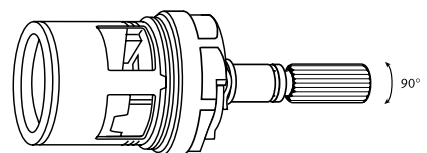

* Central Services: 01782 599258 All Franke taps are designed to conform with Water Research Council Requirements.

NB. Ceramic disc taps in certain installations or where there is a low head of water (below 4 metres) may not provide adequate flow rates. You are advised to check with your supplier.