

MTG 651 Specifications

- FA Porsche unique design statement with angular profile
- Large diagonal bowl dimension
- 2 x 90mm Wastes with Basket Strainer Wastes with pop-up waste. Capable of adaptation to take Waste Disposal Unit
- Unique adaptable Stainless Steel accessories
- Fits into 600mm base unit
- Special Accessories in Stainless Steel and Hygenia
- Hi-tech appeal in SilkSheen colours

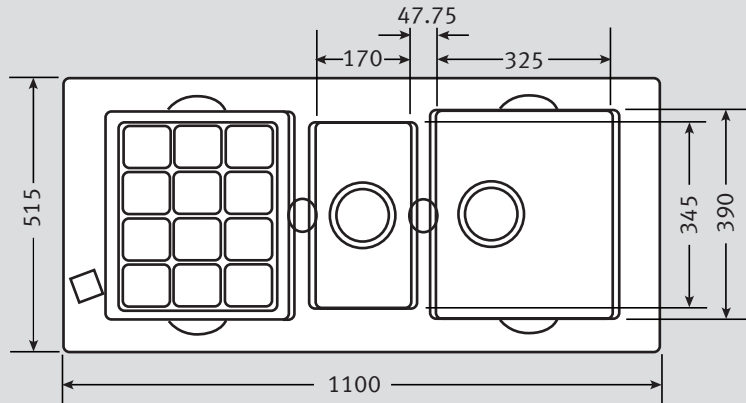

Material: Fraganite fused silica/quartz composite

Application: Inset

Bowl size: 325 x 390 x 190
175 x 345 x 130

Drainer Format: Reversible

Cut-out size: 1080 x 495 (cr=10)

Colour: Fraganite SilkSheen:
Polar White, Ivory, Platinum & Graphite

Seal: Mastic sealant

Insulation: Integral

Heat Resistance: Up to 280°C

Earthing Point: Not Applicable

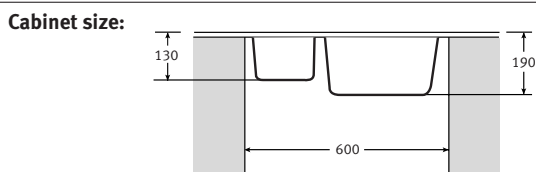

Fixing Clips: Attached

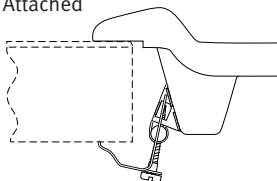

Plumbing Kit Supplied: 2 Part

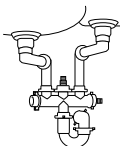

Waste: 2 x 90mm Senit basket strainer wastes with pop-up

Overflow: Not applicable

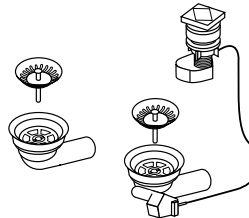

Accessories available:

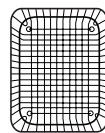

Drainer Basket
Stainless steel



Food Preparation Platter
Hygenia



Strainer Bowl
Stainless steel

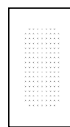

Drainer Tray
Stainless steel

Taps: Any Franke tap can be utilised with this model*.

*Ceramic disc taps in certain installations or where there is a low head of water (below 4 metres) may not provide adequate flow rates. You are advised to check with your supplier.

Guarantee: Franke sinks are guaranteed for 25 years against manufacturing defect. Franke taps are guaranteed against defective materials and workmanship for 1 year in relation to coatings and finishes, and 5 years in relation to moving parts. Franke will replace (and where appropriate repair) defective sinks. In relation to taps, Franke will where appropriate provide replacement parts for your taps or replace your taps. Any associated or ancillary costs to be incurred by you as a result of replacement of Franke sinks and taps under this guarantee shall in all cases be previously approved by Franke UK Limited.

This guarantee is in addition to and does not affect your statutory rights.