

ARX 110 17-D Specifications

- **1 x 90mm Waste with Basket Strainer Waste.** Capable of adaptation to take Waste Disposal Unit
- **Bespoke Strainer Bowl available**
- **Elongated half bowl format**
- **Waste sited at rear of bowl**

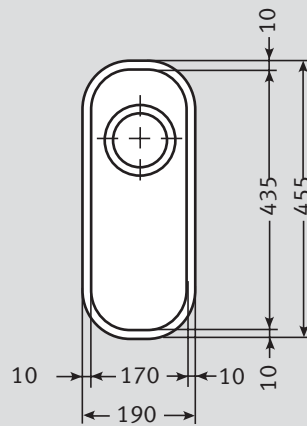

Material:	304 Austenitic 18/10 Stainless Steel	Waste:	1 x Lira 90mm Basket Strainer Waste with overflow	Overflow:	
Application:	Undermounted				
Bowl Size:	170 x 435 x 130	Accessories Available:			
Drainer Format:	Not applicable		Strainer Bowl Stainless Steel		
Cut-out Size:	Utilise template				
Colour:	Silk Stainless Steel				
Seal:	Apply sealant locally				
Insulation:	Black pads for sound				
Heat Resistance:	Up to 300°C				
Earthing Point:	Supplied with sink				
Cabinet Size:					
Fixing Clips:	Provided				
Alternative fixing systems					

Suggested Plumbing Kit: 1 part

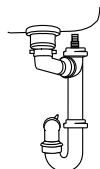

Taps: Any Franke tap can be utilised with this model*.

*Ceramic disc taps in certain installations or where there is a low head of water (below 4 metres) may not provide adequate flow rates. You are advised to check with your supplier.

Guarantee: Franke sinks are guaranteed for 25 years against manufacturing defect. Franke taps are guaranteed against defective materials and workmanship for 1 year in relation to coatings and finishes, and 5 years in relation to moving parts. Franke will replace (and where appropriate repair) defective sinks. In relation to taps, Franke will where appropriate provide replacement parts for your taps or replace your taps. Any associated or ancillary costs to be incurred by you as a result of replacement of Franke sinks and taps under this guarantee shall in all cases be previously approved by Franke UK Limited.
This guarantee is in addition to and does not affect your statutory rights.