

BBX 160 Specifications

- Undermounted Sink System
- Fits 600mm base module
- Unique high design concept with half bowl innovations
- Large diagonal bowl/deep bowl dimension
- 2 x 90mm pop-up Wastes with Basket Strainer Wastes. Capable of adaptation to take Waste Disposal Unit
- Unique stainless steel accessories including 'lock in bowl'
- Full accessory set supplied

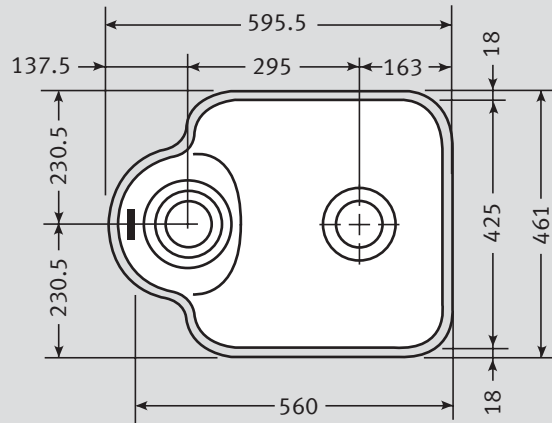

Material: 304 Austenitic 18/10 Stainless Steel

Application: Undermount

Bowl size: 560 x 425 x 175

Drainer Format: Not applicable

Cut-out Size: Utilise template

Colour: Silk Stainless Steel

Seal: Apply sealant locally

Insulation: Black Pads for heat and sound

Heat Resistance: Up to 300°C

Earthing Point: Utilise frame/earthing angle supplied

Cabinet Size:

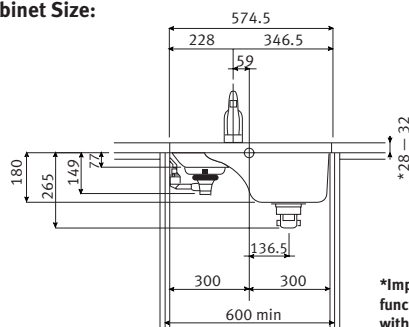

***Important - the accessories will not function unless worktop thickness is within range of 28-32mm.**

Fixing Clips: Not applicable

Suggested Plumbing Kit: 2 part

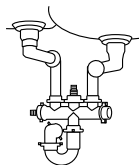

Waste: 2 x Lira 90mm Basket Strainer Wastes with overflow & pop-up assembly.

Overflow:

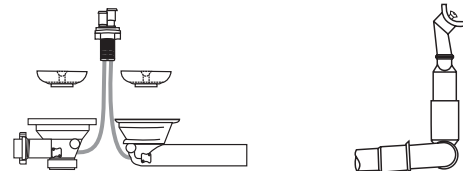

Accessories Available:

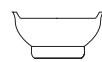

Lock-in Bowl
(with bayonet fixing)

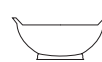

Colander
Stainless Steel

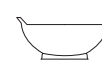

Measuring Bowl
Gleaming Stainless Steel (with calibration)

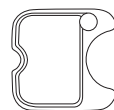

Food Preparation Platter
Hygenia (with juice collection recesses on the reverse)



Grille
Stainless Steel

Taps: Any Franke tap can be utilised with this model*. Tap sited on worktop

*Ceramic disc taps in certain installations or where there is a low head of water (below 4 metres) may not provide adequate flow rates. You are advised to check with your supplier.

Guarantee: Franke sinks are guaranteed for 25 years against manufacturing defect. Franke taps are guaranteed against defective materials and workmanship for 1 year in relation to coatings and finishes, and 5 years in relation to moving parts. Franke will replace (and where appropriate repair) defective sinks. In relation to taps, Franke will where appropriate provide replacement parts for your taps or replace your taps. Any associated or ancillary costs to be incurred by you as a result of replacement of Franke sinks and taps under this guarantee shall in all cases be previously approved by Franke UK Limited.

This guarantee is in addition to and does not affect your statutory rights.