

BOX 110 50 Specifications

- **1 x 90mm Waste with Basket Strainer Waste.** Capable of adaptation to take Waste Disposal Unit
- **Large diagonal dimension**
- **Modern 'Square' format**

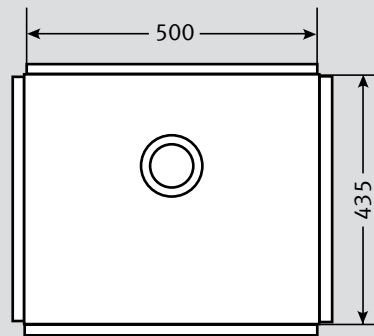
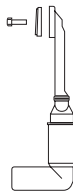
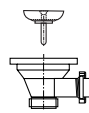
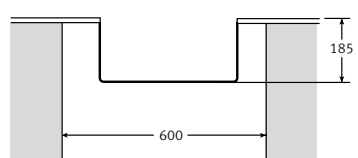
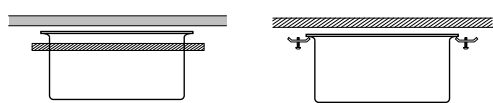
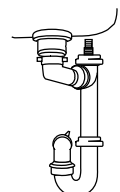

| | | | | | |
|--------------------------------|--|---|--|------------------|--|
| Material: | 304 Austenitic 18/10 Stainless Steel | Waste: | 1 x Lira 90mm Basket Strainer Waste with overflow | Overflow: |  |
| Application: | Undermounted |  | | | |
| Bowl Size: | 500 x 435 x 185 | | | | |
| Drainer Format: | Not applicable | | | | |
| Cut-out Size: | Utilise template | | | | |
| Colour: | Silk Stainless Steel | Accessories: | None available | | |
| Seal: | Apply sealant locally | | | | |
| Insulation: | Black pads | | | | |
| Heat Resistance: | Up to 300°C | | | | |
| Earthing Point: | Not applicable | | | | |
| Cabinet Size: |  | | | | |
| Fixing Clips: | Provided |  | | | |
| | | Alternative fixing systems | | | |
| Suggested Plumbing Kit: | 1 part  | Taps: | Any Franke tap can be utilised with this model*. | | |
| | | | *Ceramic disc taps in certain installations or where there is a low head of water (below 4 metres) may not provide adequate flow rates. You are advised to check with your supplier. | | |

Guarantee: Franke sinks are guaranteed for 25 years against manufacturing defect. Franke taps are guaranteed against defective materials and workmanship for 1 year in relation to coatings and finishes, and 5 years in relation to moving parts. Franke will replace (and where appropriate repair) defective sinks. In relation to taps, Franke will where appropriate provide replacement parts for your taps or replace your taps. Any associated or ancillary costs to be incurred by you as a result of replacement of Franke sinks and taps under this guarantee shall in all cases be previously approved by Franke UK Limited.

This guarantee is in addition to and does not affect your statutory rights.