

RGX 120 Specifications

- **Large & deep American style bowl**
- **2 x 90mm Wastes with Basket Strainer Wastes.** Capable of adaptation to take Waste Disposal Unit
- **Available as MD Menu pack option**

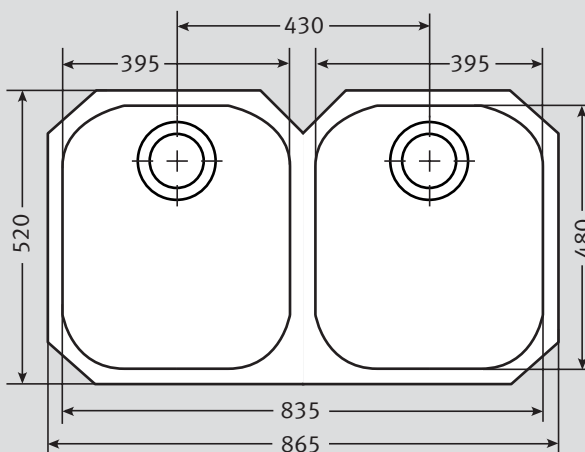

Material: 304 Austenitic 18/10 Stainless Steel

Application: Undermounted

Bowl Size: 395 x 480 x 230 (x2) Bowls welded to frame

Drainer Format: Not applicable

Cut-out Size: Utilise template

Colour: Silk Stainless Steel

Seal: Apply sealant locally

Insulation: Grey Dynaphon for heat and sound

Heat Resistance: Up to 300°C

Earthing Point: Supplied with sink

Cabinet Size:

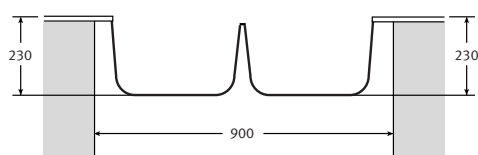

Fixing Clips: Provided

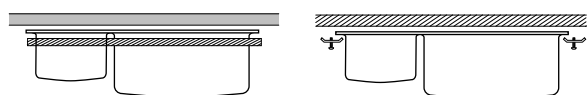

Alternative fixing systems

Suggested Plumbing Kit: 2 part

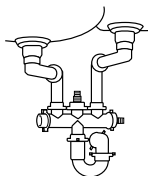

Waste: 2 x 90mm Fisc Wastes

Overflow:

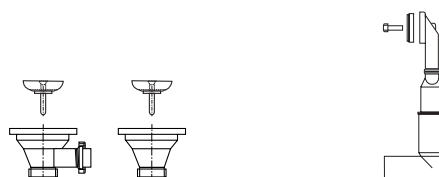

Accessories: None available

Taps: Any Franke tap can be utilised with this model*.

*Ceramic disc taps in certain installations or where there is a low head of water (below 4 metres) may not provide adequate flow rates. You are advised to check with your supplier.

Guarantee: Franke sinks are guaranteed for 25 years against manufacturing defect. Franke taps are guaranteed against defective materials and workmanship for 1 year in relation to coatings and finishes, and 5 years in relation to moving parts. Franke will replace (and where appropriate repair) defective sinks. In relation to taps, Franke will where appropriate provide replacement parts for your taps or replace your taps. Any associated or ancillary costs to be incurred by you as a result of replacement of Franke sinks and taps under this guarantee shall in all cases be previously approved by Franke UK Limited. This guarantee is in addition to and does not affect your statutory rights.