

VBK 611 Specifications

- Heavy ceramic design
- Replicates farmhouse look

N.B. Ceramic sinks may vary +/- 1% due to the firing process.

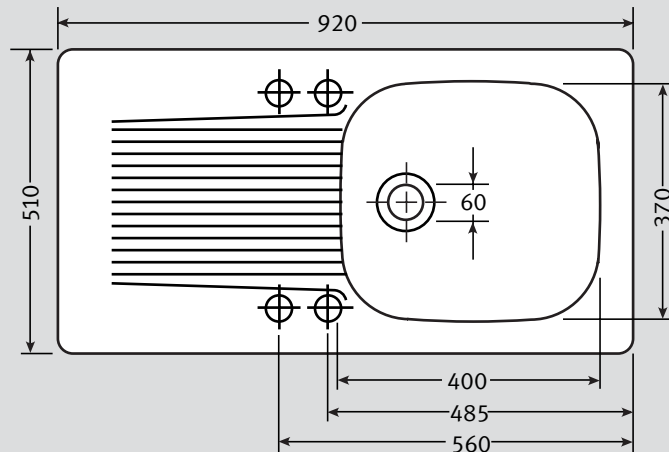
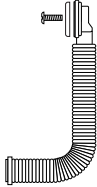
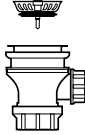
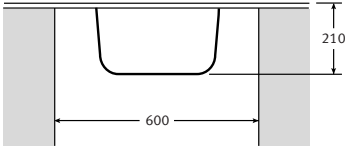
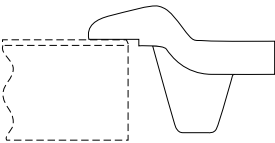
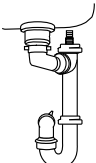

Materials:	Fireclay Ceramic	Waste:	1 x 60mm Basket Strainer Waste with overflow	Overflow:	
Application:	Inset				
Bowl size:	400 x 380 x 170				
Drainer Format:	Reversible				
Cut-out size:	880 x 460 (cr=20)				
Colour:	White	Accessories:	None available		
Seal:	Not applicable				
Insulation:	Integral				
Heat resistance:	Up to 1000°C				
Earthing Point:	Not applicable				
Cabinet size:					
Fixing Clips:	Utilise mastic 				
Suggested Plumbing Kit:	1 part (converter may be required) 	Taps:	Any Franke tap can be utilised with this model*.		

*Ceramic disc taps in certain installations or where there is a low head of water (below 4 metres) may not provide adequate flow rates. You are advised to check with your supplier.

Guarantee: Franke sinks are guaranteed for 25 years against manufacturing defect. Franke taps are guaranteed against defective materials and workmanship for 1 year in relation to coatings and finishes, and 5 years in relation to moving parts. Franke will replace (and where appropriate repair) defective sinks. In relation to taps, Franke will where appropriate provide replacement parts for your taps or replace your taps. Any associated or ancillary costs to be incurred by you as a result of replacement of Franke sinks and taps under this guarantee shall in all cases be previously approved by Franke UK Limited.

This guarantee is in addition to and does not affect your statutory rights.