

# VBK 651 Specifications

- Heavy ceramic design
- Useful rinsing bowl

**N.B.** Ceramic sinks may vary +/- 1% due to the firing process.

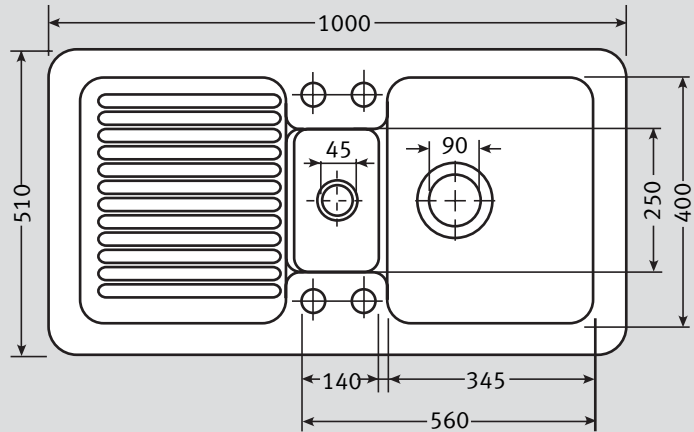

**Materials:** Fireclay Ceramic

**Application:** Inset

**Bowl size:** 345 x 400 x 170  
140 x 250 x 110

**Drainer Format:** Reversible

**Cut-out size:** 970 x 470 (cr=20)

**Colour:** White

**Seal:** Utilise mastic sealant

**Insulation:** Integral

**Heat resistance:** Up to 1000°C

**Earthing Point:** Not applicable

**Cabinet size:**

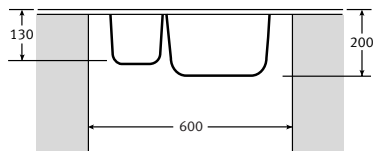

**Fixing Clips:** Utilise mastic

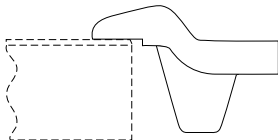

**Recommended Plumbing Kit:** 2 Part

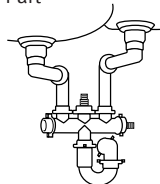

**Waste:** 1 x 90mm Basket\*  
Strainer Waste  
1 x 45mm Strainer  
Waste with plug

**Overflow:** Not applicable

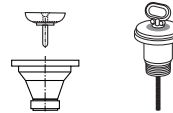

\*Zirconium finish option available at extra cost

**Accessories:** None available

**Taps:** Any Franke tap can be utilised with this model\*.

\*Ceramic disc taps in certain installations or where there is a low head of water (below 4 metres) may not provide adequate flow rates. You are advised to check with your supplier.

**Guarantee:** Franke sinks are guaranteed for 25 years against manufacturing defect. Franke taps are guaranteed against defective materials and workmanship for 1 year in relation to coatings and finishes, and 5 years in relation to moving parts. Franke will replace (and where appropriate repair) defective sinks. In relation to taps, Franke will where appropriate provide replacement parts for your taps or replace your taps. Any associated or ancillary costs to be incurred by you as a result of replacement of Franke sinks and taps under this guarantee shall in all cases be previously approved by Franke UK Limited.

This guarantee is in addition to and does not affect your statutory rights.