

VIX 651 Specifications

- 1 x 90mm Wastes with Basket Strainer Waste. Capable of adaptation to take Waste Disposal Unit
- 1 x 45mm waste and overflow
- Bespoke accessories
- Modern drainer design

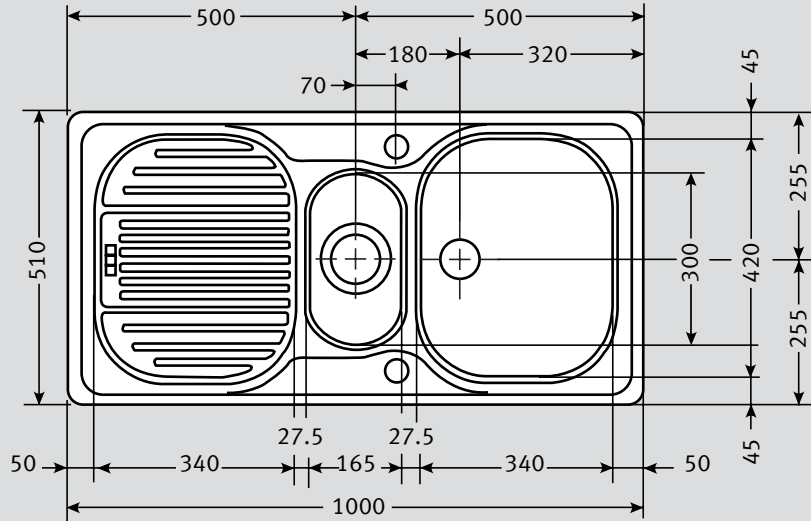

Material: 304 Austenitic 18/10 Stainless Steel

Application: Inset

Bowl Size: 340 x 420 x 175
165 x 300 x 130

Drainer Format: Reversible

Cut-out Size: 984 x 494 (cr=20)

Colour: Brushed Stainless Steel

Seal: Apply locally

Insulation: Black pads under bowl and drainer for sound insulation

Heat Resistance: Up to 300°C

Earthing Point: Utilise clip rail slots

Cabinet Size:

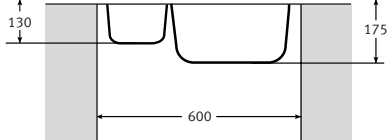

Sink Profile: Folded Edge

Fixing Clips:

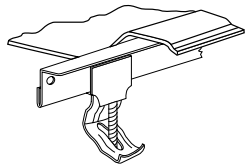
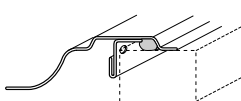

Suggested Plumbing Kit: 2 part

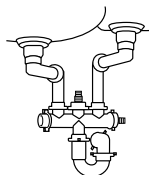

Waste: 1 x Lira 45mm Waste with plug and chain
1 x Lira 90mm Basket Strainer Waste

Overflow:

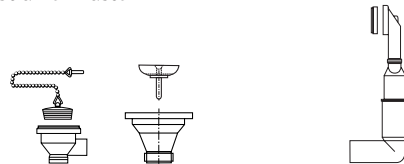

Accessories Available:



Food Preparation Platter
Mahogany

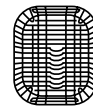

Drainer Basket
Available in White, Almond and Brown



Strainer Bowl
Available in White, Almond and Brown

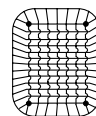

Drainer Basket
Stainless Steel



Strainer Bowl
Stainless Steel

Taps: Any Franke tap can be utilised with this model*.

*Ceramic disc taps in certain installations or where there is a low head of water (below 4 metres) may not provide adequate flow rates. You are advised to check with your supplier.

Some taps may need bracing to avoid flexing of the sink ledge.

Guarantee: Franke sinks are guaranteed for 25 years against manufacturing defect. Franke taps are guaranteed against defective materials and workmanship for 1 year in relation to coatings and finishes, and 5 years in relation to moving parts. Franke will replace (and where appropriate repair) defective sinks. In relation to taps, Franke will where appropriate provide replacement parts for your taps or replace your taps. Any associated or ancillary costs to be incurred by you as a result of replacement of Franke sinks and taps under this guarantee shall in all cases be previously approved by Franke UK Limited.

This guarantee is in addition to and does not affect your statutory rights.